

## > Pneumatic Actuator

# RAT

RAT Series Pneumatic Actuator was designed and developed based on the advanced technology and new material.



### Order Code

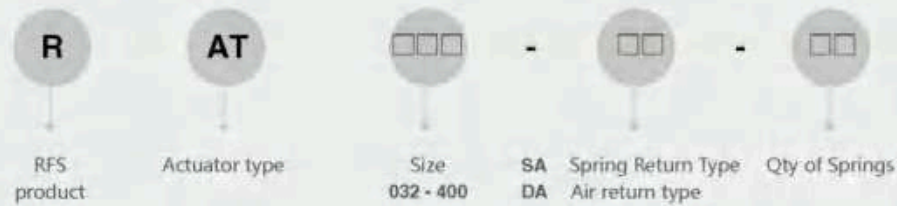

### Features

- Conform to the latest international standard: ISO5211, DIN3337, VD/VDE3845 and NAMUR.
- Excellent, compact and modernized design as well as complete specifications is good for your selection.
- All acting surfaces adopt high quality bearings, resulting in low friction, long cycle life and no noise.
- The two independent stroke adjusting devices can easily and precisely adjust at  $\pm 5^\circ$  open or close.
- Double acting type and single acting type (spring return) are with the same external structure, which is easy to install the accessories.
- NAMUR standard multifunction position indicator indicates visually.
- Pre-compressed load spring is convenient for safe mounting and teardown procedures.
- Pistons and end caps are made from die-casting aluminum which has high intensity and light weight.
- Different seal materials are available for high or low temperature
- We can offer Multi-travel rotations (e.g.  $120^\circ$   $135^\circ$   $180^\circ$ ) and three position actuators.
- Solenoid valves can be easily mounted without connecting plank.



HIDRÁULICA - NEUMÁTICA - ELECTRÓNICA  
 ☎ 1135852811    📞 114241 1370. 1142254987

www.tecnoautomat.com  
 Dirección Río de Janeiro 2740 Lanús Bs.As.

### The dimensions

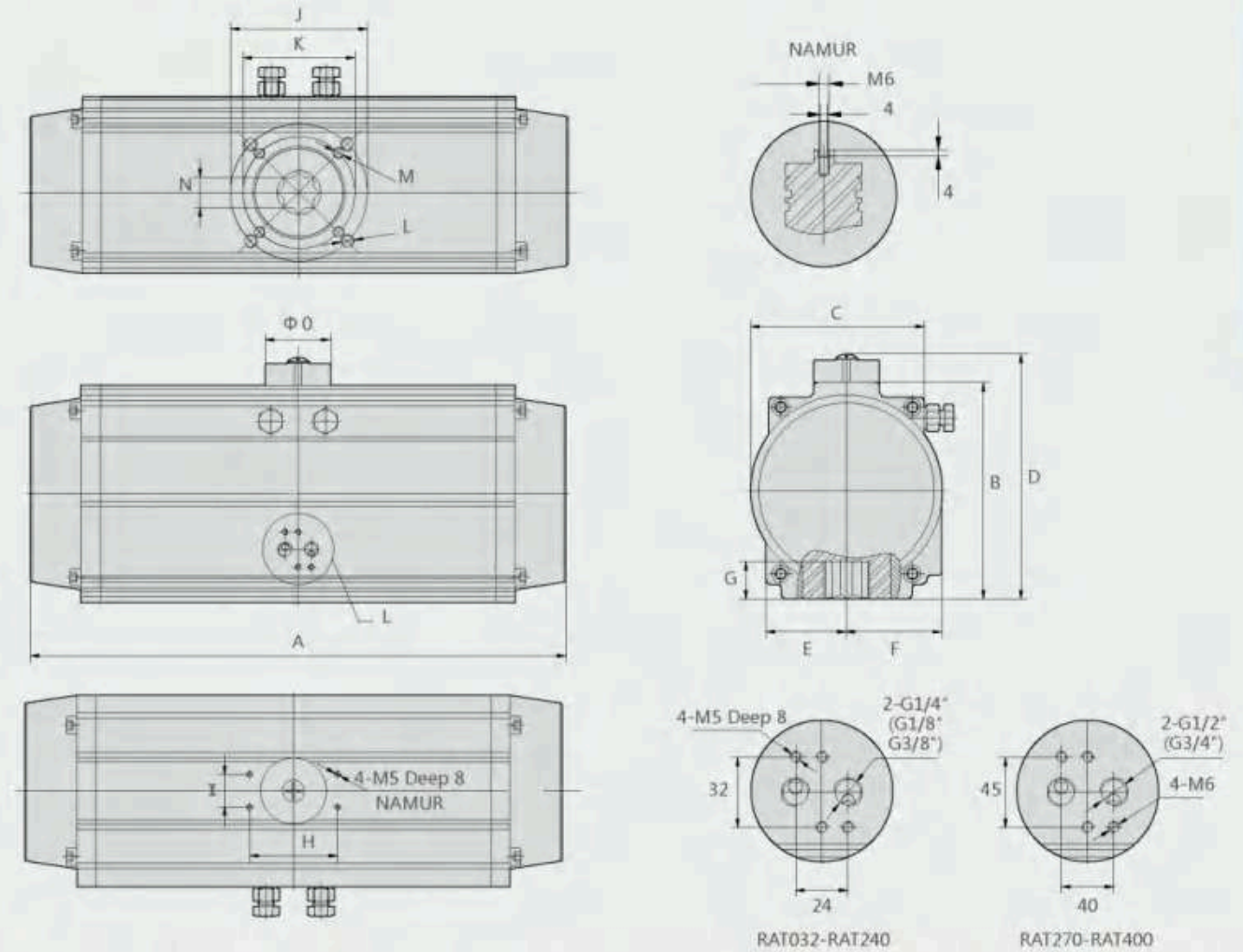

Model	A	B	C	D	E	F	G	H	I	J	K	L	M	N	O	Airconnection
RAT032-DA	112	45	51	71	22.5	28.5	12	50	25		F03/φ 36		M5x8	9	φ 40	G1/8"
RAT032-SA	142	45	51	71	22.5	28.5	12	50	25		F03/φ 36		M5x8	9	φ 40	G1/8"
RAT040-DA	124	59.5	83	86	36.4	24	14	80	30	F05/φ 50	F03/φ 36	M6x9	M5x8	11	φ 40	G1/4"
RAT040-SA	149	59.5	83	86	36.4	24	14	80	30	F05/φ 50	F03/φ 36	M6x9	M5x8	11	φ 40	G1/4"
RAT052	163.5	72	65	98	26	42	14	80	30	F05/φ 50	F03/φ 36	M6x9	M5x8	11	φ 40	G1/4"
RAT063	181	87.6	71	113	33	47	18	80	30	F07/φ 70	F05/φ 50	M8x10	M6x9	14	φ 40	G1/4"
RAT075	207	99.4	80.2	125	38.7	52.5	20	80	30	F07/φ 70	F05/φ 50	M8x12	M6x9	14	φ 40	G1/4"
RAT083	213	108.9	91.6	134.5	40	56.5	21	80	30	F07/φ 70	F05/φ 50	M8x12	M6x9	17	φ 40	G1/4"
RAT092	258	117	98.3	143	44	59	21	80	30	F07/φ 70	F05/φ 50	M8x12	M6x10	17	φ 40	G1/4"
RAT105	287	133	109.5	158.5	52	64	24.5	80	30	F10/φ 102	F07/φ 70	M10x15	M8x12	22	φ 40	G1/4"
RAT125	342.5	154.4	127.2	180.5	59.7	74	29	80	30	F10/φ 102	F07/φ 70	M10x15	M8x12	22	φ 50	G1/4"
RAT140	411	173.7	138	200	65	77	32	80	30	F12/φ 125	F10/φ 102	M12x20	M10x15	27	φ 60	G1/4"
RAT160	488	198	158.3	224	73.8	86.7	34.5	80	30	F12/φ 125	F10/φ 102	M12x20	M10x15	27	φ 60	G1/4"
RAT190	544	232.3	188.7	258	85.3	102.8	40	130	30	F14/φ 140		M16x22		36	φ 80	G1/4"
RAT210	580	257.6	210.5	284	96.5	113.2	41	130	30	F14/φ 140		M16x24		36	φ 80	G1/4"
RAT240	622	291	245	317	115	130	50	130	30	F16/φ 165		M20x26		46	φ 80	G3/8"
RAT270	766	330	273	356	126	147	50	130	30	F16/φ 165		M20x26		46	φ 80	G1/2"
RAT300	794	354	312	380	140	173	57	130	30	F16/φ 165		M20x26		46	φ 80	G1/2"
RAT350	880	410	362	436	164	195	60	130	30	F16/φ 165		M20x26		46	φ 80	G1/2"
RAT400	1067	466	450	493	145	145	60	130	30	F25/φ 254		M20x26		55	φ 80	G3/4"

Note: A120 and A180 means the acting length of  $120^\circ$  and  $180^\circ$  of rotary respectively.



Output torque of RAT spring return actuator

Air pressure (bar)		Output torque of Air supply										Spring stroke	
		3		4		5		6		7			
		0° Start	90° End	0° Start	90° End	0° Start	90° End	0° Start	90° End	0° Start	90° End		
RAT032SA	2					4.76	0.92	6.26	2.42	7.26	3.42	2.74	6.58
RAT040-SA	2					7.59	1.18	9.93	3.52	11.5	5.09	4.13	10.54
RAT052SA	5	8.48	6.28	12.64	10.44							4	6.2
	6	7.68	4.98	11.84	9.14							4.8	7.5
	7	6.98	3.78	11.14	7.94							5.5	8.7
	8			10.34	6.74	14.5	10.9					6.3	9.9
	9			9.54	5.44	13.7	9.6					7.1	11.2
	10			8.74	4.24	12.9	8.4	17.06	12.56			7.9	12.4
	11					12.1	7.1	16.26	11.26	20.42	15.42	8.7	13.7
RAT063SA	5	15	11.2	22.3	18.5	29.6	25.8					7	10.8
	6	13.5	9	20.8	16.3	28.1	23.7					8.5	12.95
	7	12	6.9	19.4	14.2	26.7	21.5					9.9	15.1
	8			18	12	25.3	19.3	32.6	26.6			11.3	17.3
	9			16.5	9.9	23.9	17.2	31.2	24.52			12.7	19.4
	10			15.3	7.7	22.6	15	29.9	22.3	37.2	29.6	14	21.6
	11			13.8	5.6	21.1	12.9	28.4	20.2	35.7	27.5	15.5	23.7
RAT075SA	5	23.4	17.8	35.1	29.5							11.9	17.5
	6	-21.1	14.3	32.8	26							14.2	21
	7	-18.7	10.8	30.4	22.5							16.6	24.5
	8			28	19	39.8	30.8					19	28
	9			25.7	15.5	37.5	27.3					21.3	31.5
	10			23.3	12	35.1	23.8	46.8	35.5	58.6	47.3	23.7	35
	11					32.7	20.3	44.4	32	56.2	43.8	26.1	38.5
RAT083SA	5	30.9	23.8	46.1	38.9							14.5	21.7
	6	28.1	19.5	43.3	34.6							17.39	26
	7	25.2	15.1	40.3	30.2							20.3	30.4
	8			37.4	25.9	52.6	41.1					23.2	34.7
	9			34.5	21.5	49.7	36.7					26.1	39.1
	10			31.6	17.2	46.8	32.4	62	47.6	77.1	62.7	29	43.4
	11					43.9	28.1	59.1	43.3	74.2	58.4	31.9	47.7
RAT092SA	5	45.7	34.7	68.6	57.6							22.5	33.5
	6	41.2	28	64.1	50.9							27	40.2
	7	36.7	21.4	59.6	44.3							31.5	46.8
	8			55.1	37.6	77.7	60.2					36	53.5
	9			50.6	30.8	73.2	53.4					40.5	60.3
	10			47.1	26.1	69.7	48.7	92.4	71.4	115.2	94.2	44	65
	11					64.2	40	86.9	62.7	109.7	85.5	49.5	73.7
RAT105SA	5	68.6	52	103.6	87							33.2	49.8
	6	61.9	42	96.9	77							39.9	59.8
	7	55.3	32.1	90.3	67.1							46.5	69.7
	8			83.7	57.1	116.6	90					53.1	79.7
	9			77	47.4	109.9	80.3					59.8	89.4
	10			70.4	37.2	103.3	70.1	137.3	104	171.2	138	66.4	99.6
	11					96.7	60.1	130.6	94	164.6	128	73	109.6
RAT125SA	5	115.5	88	173.8	146.3							59.4	86.9
	6	103.6	70.6	161.9	128.9							71.3	104.3
	7	91.8	53.5	150.1	111.6							83.1	121.6
	8			138.2	94.2	196.5	152.5					95	139
	9			126.3	76.8	184.6	135.1					106.9	156.4
	10			114.4	59.4	172.7	117.7	231	176			118.8	173.8
	11					160.9	100.4	219.2	158.7	277.5	217	130.6	191.1
	12				149	83	207.3	141.3	265.6	199.6	142.5	208.5	

Output torque of RAT spring return actuator

Air pressure (bar)		Output torque of Air supply										Spring stroke		
		3		4		5		6		7				
		0° Start	90° End	0° Start	90° End	0° Start	90° End	0° Start	90° End	0° Start	90° End			
RAT140SA	5	174.7	131.2	262.5	219							88.5	132	
	6	157	104.8	244.8	192.6							106.2	158.4	
	7	133.9	78.4	227.1	166.2							123.9	184.8	
	8			209.4	139.8	297.1	227.5					141.6	211.2	
	9			191.7	113.4	279.4	201.1					159.3	237.6	
	10			174	87	261.7	174.7	349.4	262.4	437.8	350.1	177	264	
	11					244	148.3	331.7	236	419.5	323.8	194.7	290.4	
	12					226.3	121.9	314	209.6	401.8	297.4	212.4	316.8	
	RAT160SA	5	264.6	197.1	398.3	330.8							136.5	204
		6	237.3	156.2	371	289.9							163.8	244.9
		7	210	115.4	343.7	249.1							191.1	285.7
		8	182.7	74.6	316.4	208.3	450.1	341.9					218.4	326.5
9				289.1	167.5	422.8	301.2					245.7	367.3	
10				261.8	126.7	395.5	260.4	529.2	394.1			273	408.1	
11						368.2	219.6	501.9	353.3	635.6	487	300.3	448.9	
12						340.9	178.8	474.6	312.5	608.3	446.2	327.6	489.7	
RAT190SA		5	429	320.4	644.5	535.9							217.4	326
		6	385.5	255.5	601	470.7							260.9	391.2
		7	342	190	557.5	405.5							304.4	456.4
		8			514	340.3	729.5	555.8					347.9	521.6
	9			470.6	275.1	686.1	490.6					391.3	586.8	
	10			427.1	209.9	642.6	425.4	858.1	640.9	1073.6	856.4	434.8	652	
	11					599.1	360.2	814.6	575.7	1030.1	791.2	478.3	717.2	
	12					555.6	295	771.1	510.5	986.6	726	521.8	782.4	
	RAT210SA	5	589.6	440.6	885.7	736.7							298.8	447.8
		6	529.8	351.1	825.9	647.2							358.6	537.3
		7	470.1	261.5	766.2	557.6							418.3	626.9
		8			706.4	468.1	1002.5	764.2					478.1	716.4
9				646.7	375.5	942.8	671.6					537.8	809	
10				586.9	289	883	585.1	1179.1	881.2	1475.2	1177.3	597.6	895.5	
11						823.2	495.5	1119.3	791.6	1415.4	1087.7	657.4	958.1	
12						763.5	406	1059.6	702.1	1355.7	998.2	717	1074.6	
RAT240SA		5	924	690.5	1488.1	1154.6							468.5	702
		6	829.9	550.1	1294	1014.2							562.6	842.4
		7	736.7	409.7	1200.8	873.8							655.8	982.8
		8			1107.1	733.4	1571.3	1197.6					749.5	1123.2
	9			1013.4	593	1477.6	1057.2					843.2	1263.6	
	10			919.7	452.6	1383.9	916.8	1848.1	1381	2312.2	1845.1	936.9	1404	
	11					1290.2	776.4	1754.4	1240.6	2218.5	1704.7	1030.6	1544.4	
	12					1196.5	636	1660.7	1100.2	2124.8	1564.3	1124.3	1684.8	
	RAT270SA	5	1299.7	971.2	1952.4	1623.9							658.5	987
		6	1168	773.8	1820.7	1426.5							790.2	1184.4
		7	1036.3	576.4	1689	1229.1							921.9	1381.8
		8			1557.3	1031.7	2210	1684.4					1053.6	1579.2
9				1425.6	834.3	2078.3	1487					1185.3	1776.6	
10				1293.9	636.9	1946.6	1289.6	2599.3	1942.3	3252	2595	1317	1974	
11						1814.9	1092.2	2467.6	1744.9	3120.3	2397.6	1448.7	2171.4	
12						1683.2	894.8	2335.9	1547.5	2988.6	2200.2	1580.4	2368.8	



HIDRÁULICA - NEUMÁTICA - ELECTRÓNICA  
 1135852811 114241 1370. 1142254987

www.tecnoautomat.com  
 Dirección Rio de Janeiro 2740 Lanús Bs.As.



## Output torque of RAT spring return actuator

Air pressure (bar)		Output torque of Air supply										Spring stroke	
		3		4		5		6		7			
		0°	90°	0°	90°	0°	90°	0°	90°	0°	90°	0°	90°
Model	Spring qty	Start	End	Start	End	Start	End	Start	End	Start	End	Start	End
RAT300SA	5	1603	1183									800	1220
	6	1483	1066									920	1337
	7	1330	844	2132	1646							1073	1559
	8	1177	621	1979	1423	2780	2224					1226	1782
	9			1825	1201	2626	2002	3427	2803			1380	2004
	10			1652	977	2473	1778	3274	2579	4075	3380	1533	2228
	11					2320	1556	3121	2357	3922	3158	1686	2450
	12					2014	1077	2815	1878	3686	2679	1922	2929
RAT350SA	5	2399	1739									1199	1859
	6	2120	1453									1478	2145
	7	1874	1096	3074	2296							1724	2502
	8	1627	738	2827	1938	4027	3138					1971	2860
	9			2580	1581	3780	2781	4979	3980			2218	3217
	10			2335	1223	3535	2423	4734	3622	5934	4822	2463	3575
	11					3288	2066	4487	3265	5687	4465	2710	3932
	12					3120	1537	4319	2736	5519	3936	2878	4461
RAT400SA	5	3418	2479									1709	2648
	6	2922	1670									2205	3457
	7	2647	1239	4357	2949							2480	3888
	8	2372	806	4082	2516	5191	4225					2755	4321
	9			3806	2085	5515	3794	7224	5503			3031	4752
	10			3531	1652	5240	3361	6949	5070	8658	6779	3306	5185
	11					4963	2930	6672	4639	8381	6348	3583	5616
	12					4445	2190	6154	3899	8106	5608	4101	6356

## Torque diagram of actuator

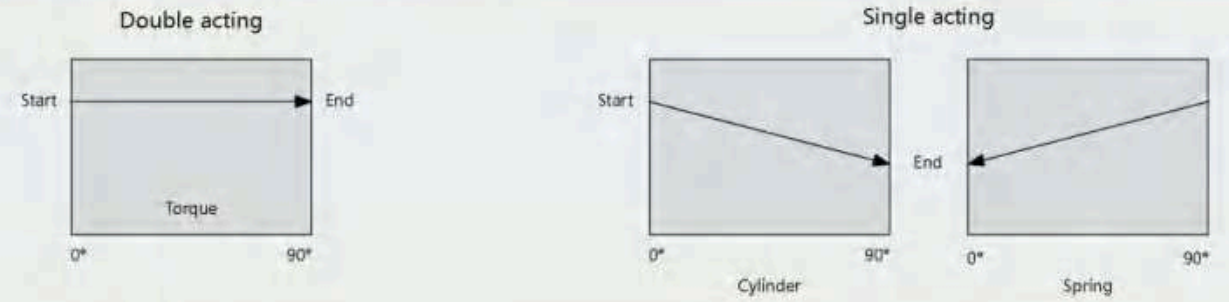

## Parts and Material

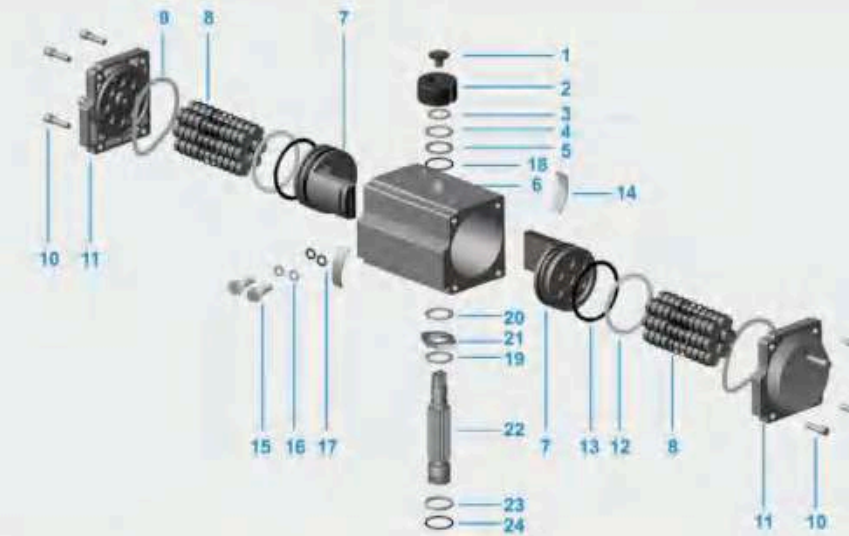

## Output torque of RAT air force return actuator

Model	Air pressure (bar)						
	2	3	4	5	6	7	8
RAT 032DA	2.78	4.20	6.00	7.50	9.00	10.00	11.50
RAT 040DA	4.44	6.56	9.83	11.72	14.06	15.63	17.97
RAT 052DA	8.32	12.48	16.64	20.8	24.96	29.12	33.28
RAT 063DA	14.64	21.96	29.28	36.6	43.92	51.24	58.56
RAT 075DA	23.5	35.3	47	58.8	70.5	82.3	94
RAT 083DA	29.7	44.5	59.4	74.2	89.1	103.9	118.8
RAT 092DA	45.5	68.2	91.1	113.7	136.4	159.2	181.9
RAT 105DA	67.88	101.82	136.76	169.7	203.64	237.58	271.52
RAT 125DA	116.6	174.9	233.2	291.5	349.8	408.1	466.4
RAT 140DA	175.48	263.22	350.96	438.7	526.44	614.18	701.92
RAT 160DA	267.4	401.1	534.8	668.5	802.2	935.9	1069.6
RAT 190DA	430.96	646.44	861.9	1077.4	1292.9	1508.4	1723.8
RAT 210DA	592.2	888.4	1184.5	1480.6	1776.7	2072.8	2369
RAT 240DA	831.9	1220.8	1627.8	2030.7	2444.6	2848.6	3255.5
RAT 270DA	1305.4	1958.2	2610.9	3263.6	3916.3	4569	5221.8
RAT 300DA	1602	2403	3205	4006	4807	5608	6409
RAT 350DA	2399	3598	4798	5998	7197	8397	9596
RAT 400DA	3418	5127	6837	8546	10255	11964	13673

No	Description	Qty	Material	Anti-corrode treatment	Optional Material	Wearing parts
1	Indicator screw	1	PA66+SS			
2	Indicator	1	POM			
3	Spring clip	1	Circlip			
4	Washer	1	Stainless steel			
5	Outside washer	1	PTFE			
6	Body	1	Aluminum alloy	Hard anodized etc.		
7	Piston	2	Cast aluminum	Hard anodized	Stainless steel	
8	Spring assembly	*	60Si2Mn2 + PA66	Dip coating		
9	End cap O-ring	2	NBR/HNBR/FKM		Viton / Silicone	X
10	Cap screw	8	Stainless steel			
11	End cap	2	Cast aluminum	powder spraying etc		
12	Bearing (Piston)	2	PTFE			
13	O-ring(Piston)	2	NBR/HNBR/FKM		Viton / Silicone	X
14	Guide (Piston)	2	POM		PTFE	
15	Adjusting bolt	2	Stainless steel			
16	Adjusting screw nut	2	Stainless steel			
17	O-ring (adjusting nut)	2	NBR/HNBR/FKM		Viton / Silicone	
18	O-ring (pinion top)	1	NBR/HNBR/FKM		Viton / Silicone	X
19	Bearing (pinion top)	1	PTFE			X
20	Inside washer	1	PTFE			
21	Cam	1	Stainless iron			
22	Pinion	1	Alloy steel	Nickel plated	Stainless steel	
23	Bearing (pinion bottom)	1	PTFE			
24	O-ring (pinion bottom)	1	NBR/HNBR/FKM		Viton / Silicone	X



## Parts Introduction

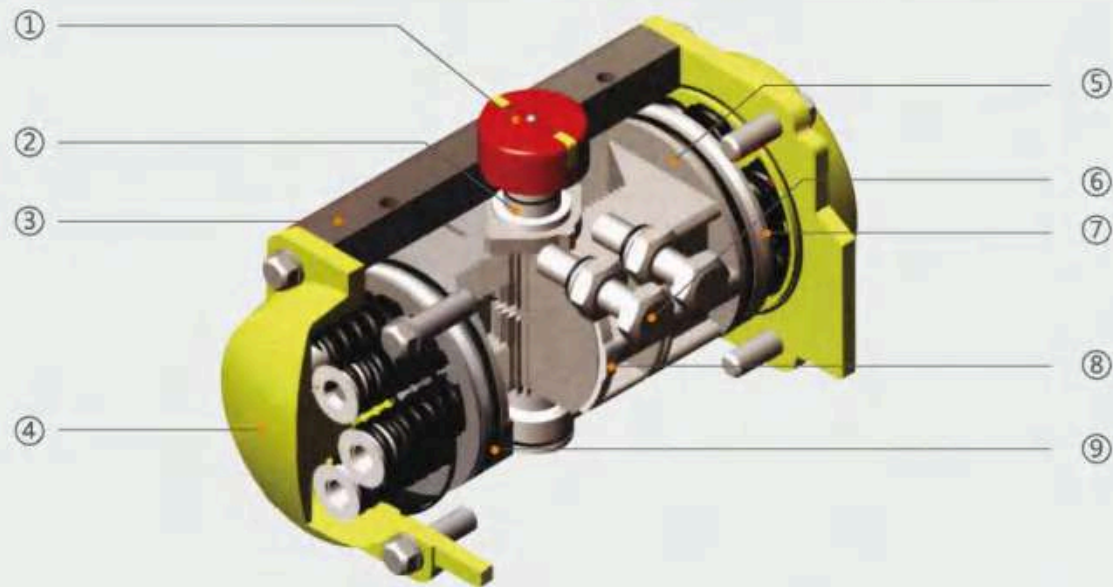

### ① Indicator

NAMUR standard indicator is convenient for mounting accessories such as Limit switch box, Positioner and so on

### ② Actuator Shaft

Nickel plated alloy steel and high-precision shaft conforms to NAMUR, ISO5211 and DIN3337 standard. The dimensions and stainless steel one can be customized.

### ③ Actuator Body

According to the different requirements, the extruded aluminum alloy ASTM6005 body can be treated with hard anodized, powder polyester painted (different colors like blue, orange, yellow and so on are available), PTFE or Nickel plated.

### ④ End Caps

Die-casting aluminum powder polyester can be painted in different colors, PTFE coated or Nickel plated.

### ⑤ Pistons

The twin rack pistons are made from Die-casting aluminum treated with hard anodized or made from Cast steel with galvanization. Symmetric mounting position, long cycle life and fast operation, reversing rotation by simply inverting the pistons.

### ⑥ Stroke adjustment

The two independent external stroke adjustment bolts can adjust  $\pm 5^\circ$  at both open and close directions easily and precisely.

### ⑦ High performance springs

Preloaded coating springs are made from the high quality material for resistant to corrosion and long service life, which can be demounted safely and conveniently to satisfy different requirements of torque by changing quantity of springs.

### ⑧ Bearings and Guides

Made from low friction and long-life compound material which to avoid the direct contact between metals and also easy to be maintained.

### ⑨ O-rings

Normal: NBR  
High temp. & low temp. : Viton or Silicone

**TECNOAUTOMAT**  
ASESORAMIENTO Y SERVICIOS

## Operating Principle

### Double action

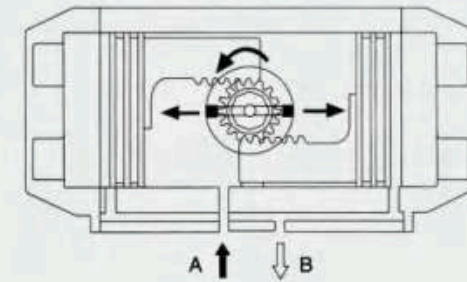

Input the air into Port A forces the pistons move outwards, the pinion turns counterclockwise and open the valve, then the air be exhausted from Port B.

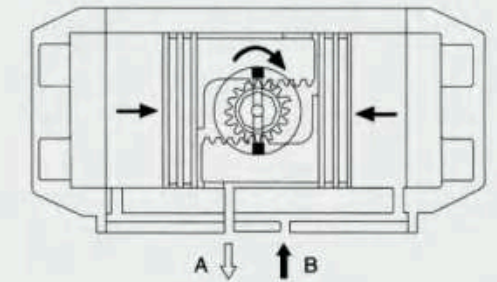

Input the air into Port B forces the pistons move inwards, the pinion turns clockwise and close the valve, then the air be exhausted from Port A.

### Single action

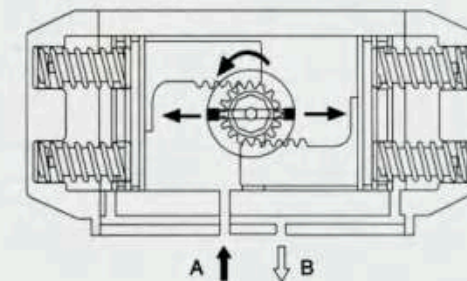

Input the air into Port A forces the pistons move outwards, the pinion turns counterclockwise and open the valve, then the air be exhausted from Port B.

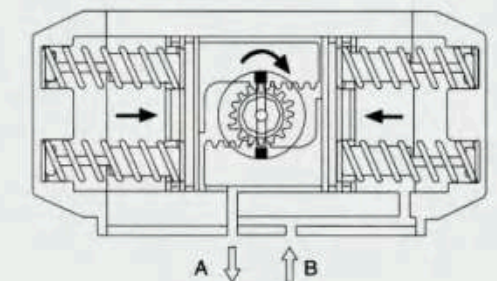

When loss air pressure or power, the stored energy in the springs forces the pistons inwards, causing the pinion turns clockwise while air be exhausted from Port

Note: 1. The standard rotation is clockwise for closing the valve and counterclockwise for opening. 2. If the direction of the piston is assembled reversely, then the standard rotation is counterclockwise for closing the valve and clockwise for opening.



## The function and usage of the actuator and the parts

- Double action actuator: open and close the valve
- Single action actuator (spring return): when the air is cut off, it will close (normal close type)
- Double control solenoid valve: the valve open when one solenoid coil power on and close when another coil power on, it has memory function. (Ex-proof type is available)
- Single control solenoid valve: the valve open or close when power on, and close or open when power off. (Ex-proof type is available).
- Limit switch box: transmit the signal of open or close of the valve remotely. (Ex-proof type is available)
- Pneumatic positioner: control the medium flow rate of the valve according to air pressure (0.2~1bar) (Ex-proof type is available)
- Electric positioner: control the medium flow rate of the valve according to electric current (4-20mA) (Ex-proof type is available)
- Electric-pneumatic transducer: transduce current signal to air pressure signal for compatibility with positioner.
- FRL: includes filter, regulation and lubrication which can clean and lubricate the connection parts
- Manual equipments: manual operate on the valve in case of the cut off or stoppage of the air or power.

## How to choose

Firstly, confirm the torque that will need during the open or close of the valve. Normally the safety factor is 15~20%. If the medium is steam or non-lubricated liquid, then set it to 25%. The safety factor for non-lubricated slurry liquid is 40% and for non-lubricated granule powder is 80%. Then check output torque table form of double action or single action, you can get a right model. On the output torque table of single action actuator, the torque on the line of spring stroke is the torque of closing the valve.

### Example

- A ball valve need torque= 280N.m
- Medium: water
- Safety factor (20%) = 280 (1+20%) =336N.m
- Air pressure= 4 bar
- According to the output torque table of double action actuator, the right model is RAT140DA, the output torque is 350.96N.m when the pressure is 4bar.



## Sample of choosing single action actuators

During the selecting of the spring return actuators, we can choose a more reasonable and economical actuator if we know the different torque of valve on opening, operation and closing.

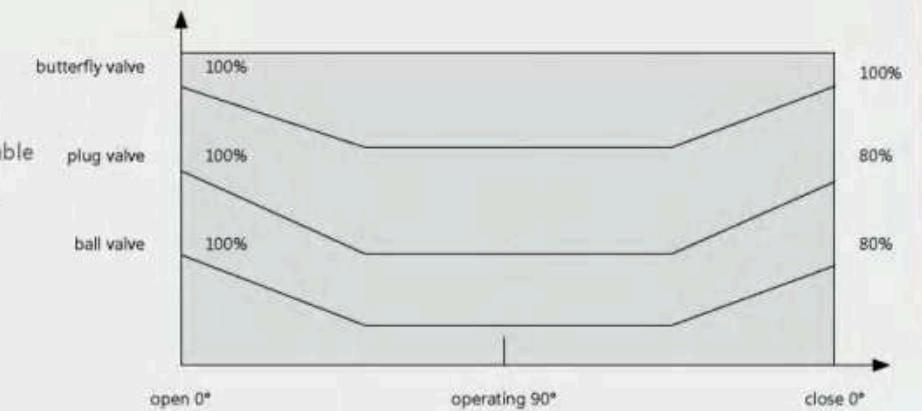

### Example

A butterfly valve need torque=80N.m

The max torque needed by the butterfly valve 80(1+30%) =104N.m

The torque after opened (operating) 104x30%=32N.m

Air supply=4bar

We can select RAT125 SA K10

- Air stroke 0° =114.4N.m >104N.m
- Air stroke 90° =59.4N.m >32N.m
- Spring stroke 90° =173.8N.m>32N.m
- Spring stroke 0° =118.8N.m> 104N.m
- The above data shows the actuator's torque can satisfy the requirement of the butterfly valve.

**Attention:** During the restoration, the spring return actuator's torque will not be affected by inputting air from port B. On the contrary, it will help restoration of springs.

## Air consumption

Air volume opening & closing					
Model	Air volume opening	Air volume closing	Model	Air volume opening	Air volume closing
RAT032	0.035 L	0.045 L	RAT140	1.7 L	2.4 L
RAT040	0.062L	0.082L	RAT160	2.6 L	3.7 L
RAT052	0.09 L	0.12 L	RAT190	4.2 L	5.9 L
RAT063	0.14 L	0.2 L	RAT210	5.7 L	8.2 L
RAT075	0.21 L	0.3 L	RAT240	9 L	12.8 L
RAT083	0.29 L	0.41 L	RAT270	12.6 L	17.9 L
RAT092	0.49 L	0.71 L	RAT300	21.4 L	30 L
RAT105	0.7 L	0.99 L	RAT350	31.2 L	43.7 L
RAT125	1.4L	1.6L	RAT400	47.9 L	67.1 L

Air consumption of double action actuator (L/min) = air volume (air volume opening + air volume closing) x (air supply (kpa) + 101.3) ÷ 101.3 x action cycle time (/min).

Air consumption of single action actuator (L/min) = air volume opening x (air supply (kpa) + 101.3) ÷ 101.3 x action cycle time (/min).



## The weight of actuator

Model	Weight(kgs)	spring weight(kgs)	Model	Weight(kgs)	spring weight(kgs)
RAT032DA	0.65	0.016	RRAT140DA	14.88	0.24
RAT040DA	1	0.0252	RAT160DA	22.98	0.37
RAT052DA	1.52	0.104	RAT190DA	40.5	0.5
RAT063DA	2.28	0.198	RAT210DA	43.5	0.5
RAT075DA	3.12	0.02	RAT240DA	65.5	1.3
RAT083DA	3.48	0.434	RAT270DA	91	1.6
RAT092DA	5	0.06	RAT300DA	114.5	2.25
RAT105DA	6.52	0.08	RAT350DA	160.5	4
RAT125DA	10.12	0.15	RAT400DA	283	5.12

## Operating conditions

### Working medium

- Dry or lubricated air or inert gas, as long as the medium is compatible with the inside parts and lubricant of the actuator.
- The dew-point temperature of the operating media is  $-20^{\circ}\text{C}$ . The dimension of the impurity particle cannot be larger than  $30\mu$ .
- If the positioner is needed, the dimension of impurity particle cannot be larger than  $5\mu$ .

### Air pressure

- 3bar to 8bar

### Working temperature

- Standard:  $-5^{\circ}\text{C}$  ~  $+80^{\circ}\text{C}$
- Low temperature type:  $-40^{\circ}\text{C}$  ~  $+80^{\circ}\text{C}$
- High temperature type:  $-10^{\circ}\text{C}$  ~  $+150^{\circ}\text{C}$

### Lubrication

- Usually the standard types no need to use lubricant. In the low temperature or high temperature occasion, it will need special lubricant.

## Three position actuator

Three position actuator provides an operation of  $0^{\circ}$ ,  $45^{\circ}$ ,  $90^{\circ}$  or the random travel of middle position. The middle position is achieved by the mechanical brake which is caused by the movement of the two auxiliary pistons. It is adjustable.

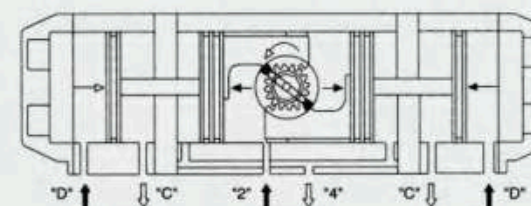

Chart 1: it is middle position, which is achieved when the air is supplied to port 2 and port D, meantime port 4 and port C are in a state of exhaust air. When the air is supplied to port D, it forces the auxiliary pistons move to the center, and make the inner pistons stopped at the setted position.

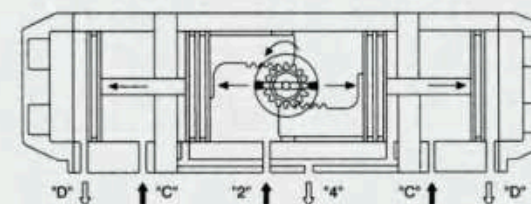

Chart 2: it is fully open position, which is achieved when the air is supplied to port 2 and port C (air to port C is optional), meantime port 4 and port D are in a state of exhaust air.

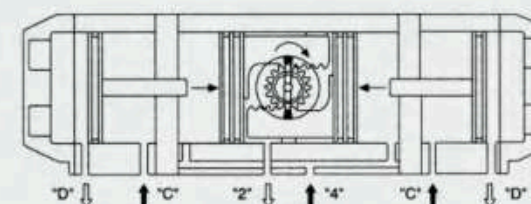

Chart 3: it is fully close position, which is achieved when the air is supplied to port 4 and port 2 is in a state of exhaust air. No need to operate port C and Port D.

### How to order

- Pneumatic actuators: double acting or spring return type (normal close or normal open)
- Please note the working pressure of the valve, working medium, working temperature and the seals.
- Solenoid valve: please note whether you need double coil or single coil, voltage and Ex-proof or not.
- Signal feedback: mechanical or approachable switch, voltage, output current and ex-proof type.
- Positioner: pneumatic positioner, electric positioner, current signal, voltage, electrical converter, ex-proof type.
- FRL
- Manual device
- Special one can be customized

### Quality Assurance

- Each actuator is tested and checked before delivery.
- Each actuator has a QC passed label.
- Each actuator is with the standard NUMAR connection and mounting size.
- Each actuator is packed by the carton.



Common problems	Checking Item	Solution
<b>Pneumatic valve does not work</b>	1. Check if the solenoid valve works normally? Is the solenoid coil failure? If the armature of the solenoid valve is jammed by impurity?	Replace the solenoid valve or coil and remove the impurity.
	2. Test the pneumatic actuator with air supply to check if the o-ring and cylinder are broken.	Replace the broken o-ring and cylinder.
	3. Is impurity blocking the valve?	Clean out the impurity, replace the broken parts.
	4. Is the handle of the manual device at the manual state?	Put the handle to the pneumatic state.
<b>Acting slowly</b>	1. Is the air supply pressure insufficient?	Increase the air pressure (0.4-0.7Mpa)
	2. Is the output torque of pneumatic actuator not enough?	Select a bigger model of the pneumatic actuator
	3. Is the valve stem or other parts assembled too tight?	Re-assemble and adjust the valve
	4. Is the air supply pipe blocked making the air flow too small?	Clean out the block and replace the filter stem.
<b>The feedback has no signal</b>	1. Check if the power is short circuit or open circuit	Examine and repair the circuit
	2. Is the cam of the feedback in the incorrect position?	Adjust the cam to the correct position
	3. Is the micro switch broken?	Replace the micro switch